

Review paper on multi-level discrete wavelet transform using different technique

Nagma Mansooy¹ and Sohed Munir²

M. Tech. Scholar, Department of Electronics and Communication, LNCT, Bhopal¹
Associate Professor, Department of Electronics and Communication, LNCT, Bhopal²

Abstract

A relative report are diverse kinds of discrete wavelet change (DWT) engineering is exhibited in the paper. DWT is give great determination in both time and recurrence. Numerous kinds of procedure are planned into DWT design. In any case, 2's supplement based plan is the best outline of other plan. It is the fundamental issue of this outline in various full snake is more required. Defeat this issue is intended to canonic marked digit (CSD) has been connected DWT engineering to decrease the full viper. CSD based DWT engineering is appropriate for some advanced flag handling (DSP) applications. The diagram of CSD strategy displayed in this paper.

Keywords

Discrete wavelet transform (DWT), 2's Complement technique, CSD technique.

1.Introduction

The persistent improvement in workstation innovation upgrades utilizing advanced photographs. Together with this comes the outrageous issue of putting away and moving the enormous measure of information speaking to the depictions while uncompressed [1]. Interactive media records, i.e. sound and video require lovely an enormous carport capacity and transmission data transfer capacity. Regardless of fast development in mass carport thickness, lifted speed of the processor and the general execution of the virtual sight and sound frameworks, the need for records stockpiling capacity and records transmission data transfer capacity save on expanding the capacities of new innovation [1]. The Discrete Wavelet improve (DWT) has discovered numerous applications in virtual flag preparing, on account of the green calculation and the adequate homes for non-stationary flag examination [2]. Lately it has ended up being one of the most extreme utilized methods for picture pressure. The photograph is totally a type of excess measurements, i.e. it is created the equivalent data from a one of a kind disposition of view. By utilizing the use of records pressure methodologies, it's far practicable to dispose of some of the repetitive actualities contained in the pix.

Photograph pressure limits the span of a photo record without corrupting the special case of the picture of an unsuitable stage. The markdown in size of record lets in more prominent photographs to be spared in a chosen amount of plate or memory territory [3]-[5]. In this work, we have done the pressure set of guidelines the utilization of essential Haar wavelet, in VHDL programming dialect. For that we have taken 8X8 grid in both, while in transit to diminish the many-sided quality of data on the essential models. This fresh debut has demonstrated an astonishing guarantee towards data/photograph pressure. The contemporary JPEG2000 boundless is in like manner fundamentally in view of this redesign coding/calculation [6]-[7].

On this artistic creation, handiest grayscale picture are considered. In any case, wavelet changes and pressure techniques are likewise applicable to the shading photographs with 3 hue parts. We should apply this change to every one of this shading factor autonomously and should regard the outcome as a variety of vectors esteemed wavelet coefficients.

The point of executing a correspondence chip is to manage the usefulness, throughput and inactivity of the basic standard utilizing minimal measure of energy and zone cost (Gemmeke, 2004). A Majority of the regular procedures that are utilized to decrease power or region (as a prevailing measure of cost) are building. In any case, these procedures have been essentially heuristic and they are without a built up efficient path for exchanging off throughput, power and zone. Innovation scaling helps the originators to have more options for supply voltages and transistor edges, other than an assortment of circuit plan strategies like the utilization of rest modes (Yamada, 2006). Every one of these systems present a little power-execution tradeoff, making design choice be more mind boggling and draw more consideration. In this way, it is planned to build up a technique that is equipped for limiting force and zone in the meantime, subjected to given throughput and idleness requirements [8].

2.Direct wavelet transform

The idea of discrete wavelet change is presented here [9]. Through the discrete wavelet change investigation, the entire info esteem ought to be examined and additionally given to the procedure. The information ought to be as time space. The DWT is utilized to change the information from a period space into a recurrence area [10, 11]. The recurrence areas have numerous highlights and by the utilization of recurrence space it can without much of a stretch distinguish the sound flag [12]. From the above advances points of interest of DWT is known and now the constant wavelet change is examined. Here, the discrete wavelet change is transmitted by a persistent wavelet change thus an exchange on the constant wavelet change and its highlights must be made. The ceaseless wavelet change is a moved form of the wavelet work $\tilde{\psi}$, and the primary capacity of CWT is utilized to isolate a persistent wavelet capacities into a little wavelet.

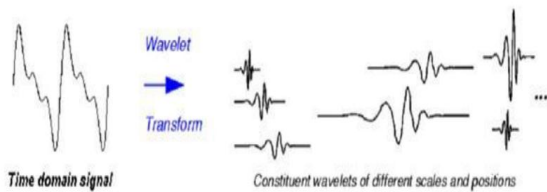

Figure 1 Waveform represented of DWT

The model utilized as a part of [9] to execute the tree structure of Direct Wavelet Packet Transform (DWPT) depends on the separating procedure. Figure 1 portrayed an entire 3-level Direct WPT. In this figure G and H is the high pass and low pass channel separately [13].

Calculation period is the wide assortment of the info cycles for one time delivers yield tests. In vogue, the calculation length is $M=$ for a j -level DWPT. The term of the 3-organize calculation is eight. observe 1, The Sub band Coding set of tenets for instance, expect that the bona fide sign $X[n]$ has N -design focuses, traversing a recurrence band of 0 to π rad/s. At the main deterioration level, the sign surpassed through the high pass and low sidestep channels, finished subsampling by means of 2. The yield of the high pass sift through has $N/2$ -test factors (accordingly 50% of the time determination) notwithstanding it handiest traverses the frequencies $\pi/2$ to π rad/s (thusly twofold the recurrence choice) [14].

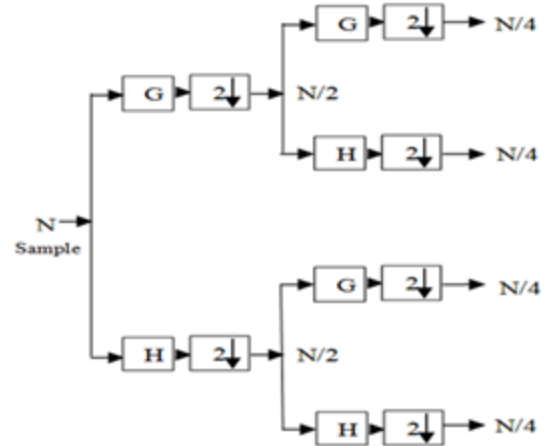

Figure 2 Block Diagram of 2-D DWT

The output of the low-bypass filter additionally has $N/2$ - sample points, but it spans the opposite half of the frequency band, frequencies from 0 to $\pi/2$ rad/s. again low and excessive-pass filter output passed via the identical low skip and excessive pass filters for similarly decomposition [11, 12].

The output of the second one low skip clear out followed by way of sub sampling has $N/4$ samples spanning a frequency band of zero to $\pi/4$ rad/s, and the output of the second high idestep sift through saw by utilizing sub testing has $N/4$ tests spreading over a recurrence band of $\pi/4$ to $\pi/2$ rad/s. the second one extreme sidestep separated sign constitutes the second phase of DWPT coefficients. This sign has half of the time determination, however two times the recurrence choice of the principal level sign. This procedure proceeds till two examples are cleared out. For this particular occasion there would be three scopes of deterioration, each having half of the scope of tests of the previous degree. From the above advances points of interest of DWT is known and now the ceaseless wavelet change is contemplated. Here, the discrete wavelet change is transmitted by a ceaseless wavelet change thus a discourse on the constant wavelet change and its highlights must be made. The constant wavelet change is a moved variant of the wavelet work $\tilde{\psi}$, and the fundamental capacity of CWT is utilized to separate a persistent wavelet capacities into a little wavelet.

The DWT of the first flag is then acquired by connecting all coefficients beginning from the last level of disintegration (staying two examples, for this situation).

The DWT will then have an indistinguishable number of coefficients from the first flag [15].

3.Literature review

Rakesh Biswas et al. [1], this paper shows a high accuracy low territory lifting based engineering for the brought together execution of both lossy and lossless 3D multi-level Discrete Wavelet Transform (DWT) utilizing LeGall 5/3 wavelet and Cohen-Daubechies-Feauveau (CDF) 9/7 wavelet. The proposed framework is parallel-pipelined, and asset is shared between the lossy and lossless modes, creating a throughput of 2 yields/clock and accomplishing a fast and low territory arrangement. The information width of the outline is taken as 20 bits to achieve a high PSNR esteem for multi-level 3D DWT. Focusing on a convenient and ongoing arrangement, the proposed engineering was effectively actualized on Xilinx Virtex-5 arrangement Field Programmable Gate Array (FPGA), accomplishing a clock speed of 290 MHz with a power utilization of 467 mW at 200 MHz clock recurrence. The outline has additionally been executed in UMC 90 nm CMOS innovation, which expends 329 mW control at 200 MHz clock recurrence. The proposed arrangement might be designed as lossless or lossy pressure, in the field of 3D picture pressure framework, as per the need of the client.

Linning Ye et al. , “Memory Efficient Multilevel Discrete Wavelet Transform Schemes for JPEG2000”, [2], when working with the line-primarily based wavelet transform, JPEG2000 wishes to buffer many sub-band lines for future block coding. This coding buffer occupies most people of the reminiscence utilization in a JPEG2000 gadget. On this paper, we first use the multilevel blockprimarily based wavelet remodel, after which make use of the multilevel stripe-based wavelet remodel to recognise JPEG2000 coding. The system schemes of the multilevel block-based totally wavelet remodel and the multilevel stripe-based totally wavelet transform for JPEG2000 are provided. The proposed schemes can effectively control the wavelet coefficient output sample, and thus lessen the reminiscence usage of JPEG2000 coding buffer. compared with the line-based totally wavelet remodel, the proposed schemes reduce greater than 50% reminiscence usage of the JPEG2000 system and slightly decrease the memory bandwidth. via preserving the blocks/stripes in on-chip memory, which do no longer depend upon the photo length, the reminiscence bandwidth of the JPEG2000 system can be in addition significantly decreased. The gain

of the stripebased wavelet remodel over the block based wavelet remodel lies in that it occupies an awful lot much less inner memory.

R. Praisline Jasmi et al. “Comparison of Image Compression Techniques using Huffman Coding, DWT and Fractal Algorithm”, [3], photograph compression is one of the positive strategies in exceptional varieties of multi-media services. Picture Compression method have been emerged as one of the most vital and successful programs in image evaluation. in this paper the notion of photograph compression the usage of easy coding strategies referred to as Huffman; Discrete Wavelet transform (DWT) coding and fractal algorithm is achieved. These strategies are easy implementation and make use of much less memory. Huffman coding approach includes in reducing the redundant facts in input images. DWT can be able to enhance the quality of compressed picture. Fractal algorithm entails encoding technique and offers better compression ratio. by the usage of the above algorithms the calculation of height signal to noise ratio(PSNR), suggest rectangular errors(MSE) and compression ratio(CR) and Bits in step with pixel(BPP) of the compressed image via giving 512×512 input pictures and also the comparison of performance analysis of the parameters with that above algorithms is finished. The result really explains that Fractal set of rules affords higher Compression ratio (CR) and top signal to noise ratio (PSNR).

Rashmita Sahoo et al., “Haar Wavelet Transform Image Compression using Run Length Encoding”, [4], in present day generation memory storing area is not a completely big deal. however when it comes to a transportable gadget i.e. a digital digicam with net in addition to communication facility, then the bandwidth for communicate as well as storage are of serious issue. Huge beneficial statistics must be stored and retrieved efficaciously for realistic functions. The Haar wavelet, which is the handiest of all of the 2d DWT, in conjunction with thresholding has been carried out on a JPEG photo. After that Run duration Entropy Coding has been adopted. that is the novel method that authors have proposed for compression of image the usage of parameter CR (Compression Ratio) without dropping the parameter PSNR, the first-class of picture, the use of less bandwidth.

B. Ramkumar et al., “Low-Power and Area-Efficient Carry Select Adder”, [5], carry Select Adder (CSLA) is one of the quickest adders utilized as a part of

numerous information handling processors to perform quick number juggling capacities. From the structure of the CSLA, it is clear that there is extension for diminishing the zone and force utilization in the CSLA. This work utilizes a straightforward and proficient entryway level change to altogether diminish the range and force of the CSLA. In light of this change 8-, 16-, 32-, and 64-b square-root CSLA (SQRT CSLA) structural engineering have been produced and contrasted and the general SQRT CSLA structural planning. The proposed outline has diminished territory and force as contrasted and the standard SQRT CSLA with just a slight increment in the deferral. This work assesses the execution of the proposed outlines regarding deferral, region, power, and their items by hand with legitimate exertion and through specially craft and format in 0.18- μ m CMOS process innovation. The outcomes investigation demonstrates that the proposed CSLA structure is superior to the normal SQRT CSLA.

4. Low-complexity designs for DWT

DWPT computation is nothing but two-channel FIR filter computation. Low-pass and high-pass down sampled filter computations are performed on the input to calculate the DWPT coefficients. Low-pass down sampled filter is the average between two samples and high-pass filter is the difference b/w two samples. The DWPT algorithms for 1-level decomposition are given as;

$$Y_{high}[k] = \sum_n h[n] * x[2k - n] \quad (1)$$

$$Y_{low}[k] = \sum_n g[n] * x[2k - n] \quad (2)$$

Where $x(n)$ is the input and $Y_{high}[k]$ & $Y_{low}[k]$ are respectively the low-pass and high-pass DWPT coefficients, $h[n]$ and $g[n]$ are respectively, the low-pass and high-pass filter coefficients. We have assumed the Daubechies four tap (Daub-4) filter coefficients for the low-pass filter proposed design. However, similar type of design can be derived for other type of wavelet filters as well. The Daub-4 low-pass filter coefficients are taken from [7]. The corresponding high-pass filter coefficients are calculated using the following relation:

$$g(n) = (-1)^k h(N - n) \quad (3)$$

Table 1 Low and high-pass Daub-4 filter coefficients

h(0)	0.4829629131	0.01111011	0.10000 101
h(1)	0.8365163037	0.11010110	0.00 101010
h(2)	0.2241438680	0.00111001	0.0100 1001
h(3)	-0.129409522	1.11011111	1.00 100001
g(0)	-0.129409522	1.11011111	1.00 100001
g(1)	-0.224143868	1.11000111	1.0 1001001
g(2)	0.836516303	0.11010110	0.00 101010
g(3)	-0.482962913	1.10000101	1.10000 101

The binary digit 1 shown in bold face represents -1 of the CSD digit. Where, $h(n)$ and $g(n)$ are, respectively, the low and high-pass filter coefficients. N is the filter order. The 8 bit 2's complement and CSD representation of the low and high-pass filter coefficient are given in Table 1. Equation can be rewritten four-tap FIR filter as:

$$Y_h[k] = [h(0) + h(1)Z^{-1} + h(2)Z^{-2} + h(3)Z^{-3}] X(n) \quad (4)$$

$$Y_l[k] = \left[\frac{g(0) + g(1)Z^{-1} + g(2)Z^{-2} + g(3)Z^{-3}}{Z^{-3}} \right] X(n) \quad (5)$$

Where Z^{-1} operator represents one sample delay in Z -domain.

5. Proposed architecture

On this paper, the original signal $X[n]$ has N - sample points, is exceeded thru 1×2 demultiplier. whilst pick out line is 0 then we get even pattern and whilst choose line is 1 then we get abnormal sample. After that we've got handed those samples through CSD based totally low-skip filter out, equal method with high-skip filter. Now we get $N/2$ sample s at the primary decomposition level output of CSD primarily based high-skip (Y_H) and low-pass filter out (Y_L). At the second decomposition level, the output of CSD based totally low-skip and high-bypass clear out handed through a sign in unit. Now the output of sign up unit surpassed via mux. whilst the pick line 0, we get CSD primarily based low-skip filter out output and while the choose line 1, we get CSD primarily based high-skip filter out. Now we've surpassed mux output via CSD primarily based low-pass filter out then we get Y_{LL} & Y_{LH} output now equal method implemented with the CSD based high-skip filter out we get Y_{HL} & Y_{HH} . on the 0.33 decomposition degree, the time period is doubled and frequency can be $1/2$, and the output of CSD primarily based low-pass and excessive-skip filter out is passed through a check in unit. Now the output of check in unit is surpassed via mux. when the choose line is 00.

Now finally we have passed mux output through CSD based low pass filter and high pass filter we get $Y_{LLL}, Y_{LHL}, Y_{HLL}, Y_{HHL}$ and $Y_{LLH}, Y_{LHH}, Y_{HLH}, Y_{HHH}$.

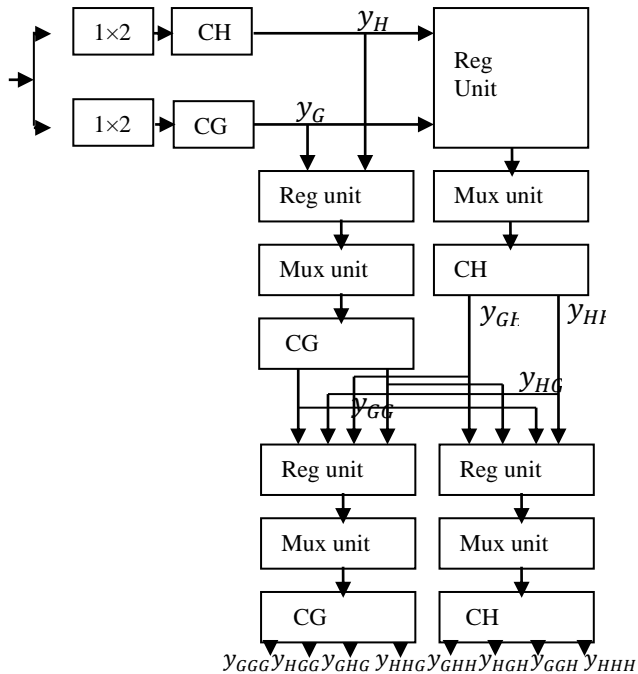

Figure 3 3-Level CSD design based DWPT, CG and CH means the CBL design based low & high-pass filter

6. Simulation result

We have implemented multiplier based (MB) architecture and common Boolean logic based (CBL) architecture for DWT by different approaches. The delay and area evaluation methodology considers all gates to be made up of AND, OR, and Inverter (AOI), each having delay equal to 1 unit and area equal to 1 unit. We then add up the number of gates in the longest path of a logic block that contributes to the maximum delay. The area evaluation is done by counting the total number of AOI gates required for each logic block.

7. Conclusion and future work

We have used the CSD number system to represent the filter coefficients of the wavelet filter with minimum number of ones. Consequently, the number of FAs of the design will be reduced by nearly 50% of these of the 2's complement design. Then we carried out the CBL technique to similarly reduce the electricity and location. on this structure the velocity of the enter sampling extended and used of the low

and excessive skip filter. Low pass clear out is the average between sample and high skip clear out is the difference among two samples. there's no on-chip reminiscence and memory get right of entry to at some stage in the computation, so which can reap widespread discount in each die region and power dissipation. On this paper architecture is appropriate for excessive velocity online applications. With this architecture the speed of the wavelet packet transforms is increased, occupied regions of the circuit is reduced about 50% in the previous convolution primarily based structure and decreases the electricity approximately 15-25% inside the previous convolution based totally structure. It has 100% hardware utilization efficiency.

References

- [1] Biswas R, Malreddy SR, Banerjee S. A high precision-low area unified architecture for lossy and lossless 3d multi-level discrete wavelet transform. IEEE Transactions on Circuits and Systems for Video Technology. 2017.
- [2] Ye L, Hou Z. Memory efficient multilevel discrete wavelet transform schemes for jpeg2000. IEEE Transactions on Circuits and Systems for Video Technology. 2015; 25(11):1773-85.
- [3] Jasmi RP, Perumal B, Rajasekaran MP. Comparison of image compression techniques using huffman coding, DWT and fractal algorithm. In computer communication and informatics (ICCCI), international conference on 2015 (pp. 1-5). IEEE.
- [4] Sahoo R, Roy S, Chaudhuri SS. Haar wavelet transform image compression using run length encoding. In communications and signal processing (ICCSP), International conference on 2014 (pp. 071-5). IEEE.
- [5] Ramkumar B, Kittur HM. Low-power and area-efficient carry select adder. IEEE Transactions on Very Large Scale Integration (VLSI) Systems. 2012; 20(2):371-5.
- [6] Patil R, Kolte MT. Low power high speed VLSI architecture for 1-D discrete wavelet transform. In electrical, electronics, signals, communication and optimization (EESCO), international conference on 2015 (pp. 1-6). IEEE.
- [7] Tewari G, Sardar S, Babu KA. High-speed & memory efficient 2-d dwt on xilinx spartan3a dsp using scalable polyphase structure with da for jpeg2000 standard. In electronics computer technology (ICECT), 3rd international conference on 2011 (pp. 138-42). IEEE.
- [8] Haveliya A. Design and simulation of 32-point FFT using radix-2 algorithm for FPGA implementation. In advanced computing & communication technologies (ACCT), second international conference on 2012 (pp. 167-71). IEEE.
- [9] Sriraman L, Prabakar TN. Design and implementation of two variable multiplier using KCM and Vedic

- mathematics. In recent advances in information technology (RAIT), 1st international conference on 2012 (pp. 782-7). IEEE.
- [10] Tiwari HD, Gankhuyag G, Kim CM, Cho YB. Multiplier design based on ancient indian vedic mathematics. In SoC design conference, 2008. ISOC'08. International 2008 (pp. II-65). IEEE.
 - [11] Dhoka M, Kadam J. Digital watermarking for medical images using biorthogonal wavelet filters and transformed watermark embedding. International Journal of Advanced Computer Research. 2014; 4(2):705-12.
 - [12] Mallat SG. A theory for multiresolution signal decomposition: the wavelet representation. IEEE transactions on pattern analysis and machine intelligence. 1989; 11(7):674-93.
 - [13] Alam M, Rahman CA, Badawy W, Jullien G. Efficient distributed arithmetic based DWT architecture for multimedia applications. In system-on-chip for real-time applications. proceedings. The 3rd IEEE international workshop on 2003 (pp. 333-36). IEEE.
 - [14] Martina M, Masera G. Low-complexity, efficient 9/7 wavelet filters VLSI implementation. IEEE Transactions on Circuits and Systems II: Express Briefs. 2006; 53(11):1289-93.
 - [15] Martina M, Masera G. Multiplierless, Folded 9/7-5/3 wavelet VLSI architecture. IEEE Transactions on Circuits and Systems II: Express Briefs. 2007; 54(9):770-4.