

Enhancement of adaptive fuzzy inference-system for “variable speed control of wind power generation systems”

Amit Singh Sengar¹, Rohit Kumar Gupta² and Amol Kumar Barve³

M.Tech scholar, Department of Electrical Engineering , LNCT Bhopal, India¹

Professor, Department of Electrical Engineering , LNCT Bhopal, India²

Professor and HOD, Department of Electrical Engineering , LNCT Bhopal, India³

Abstract

In this paper, a new approach of optimal Economical sizing of a Hybrid PV-Wind energy system is presented in order to assist the designers to take into consideration both the economic and ecological aspects. This thesis presents the various optimization techniques to design the hybrid PV-wind system. The hybrid system consists of photovoltaic panels and wind turbines. Fuzzy logic Based Optimization techniques are utilized to minimize the formulated objective function, i.e. total cost which includes initial costs, yearly replacement cost, yearly operating costs and maintenance costs and salvage value of the proposed hybrid system. It also presents the application and performance comparison system with fuzzy and without fuzzy techniques for optimal sizing of Hybrid PV/Wind energy system. One computer program and one matlab model are designed, using MATLAB code to formulate the optimization problem by computing the coefficients of the objective function. Finally, the optimal solution is achieved by fuzzy logic optimization method.

Keywords

Hybrid PV/Wind generation system, Fuzzy logic controller, Power quality, MPPT, Mat lab/simulink.

1.Introduction

Renewable energy sources (RES) such as Solar, Wind, Geothermal, Tidal, Hydro etc. are inexhaustible by nature. The RES have been found promising towards building sustainable and ecofriendly power generation. Due to the limitation of conventional resources of fossil fuels, it has compelled the evolution of hybrid power system. Therefore, new ways to balance the load demand is by integrating RES into the system. Hybrid system enables the incorporation of renewable energy sources and transfers the dependency on fossil fuels, while sustaining the balance between supply and demand. The significant characteristic of hybrid power system includes, system reliability, operational efficiency [1]. The hybrid power system enables to overcome the limitations in wind and photovoltaic resources since their performance characteristics depends upon the unfavorable changes in environmental conditions. It is probable to endorse that hybrid stand-alone electricity generation systems

are usually more reliable and less costly than systems that depend on a single source of energy [2]. On other hand one environmental condition can make one type of RES more profitable than other. For example, Photovoltaic (PV) system is ideal for locations having more solar illumination levels and Wind power system is ideal for locations having better wind flow conditions [3].

For RES especially the variable speed wind energy conversion systems, Permanent Magnet Synchronous generator (PMSG) is gaining popularity. PMSG have a loss-free rotor, and the power losses are confined to the stator winding and stator core. A multi-pole PMSG connected to power converter can be used as direct driven PMSG in locations with low wind speed there by eliminating the gearbox which adds weight, losses, cost and maintenance [4]. A gearless construction of wind conversion system represents an efficient and reliable wind power conversion system. In a PV system, a solar cell alone can produce power of 1 to 2 watt [5]. The solar cell is modeled by two diode model [6]. The solar cells are connected in series and parallel to form a PV panel or module. The PV modules are connected in series and parallel to form a PV array in order to generate appropriate amount of power.

In general, power quality and reliability in renewable systems are very important elements. One disadvantage of a wind energy system is that it exposes reactive power to the asynchronous generator from a network or capacitor groups. Constant speed energy systems operate in constant frequency and constant speed. As the wind speed is variable, the wind turbine speed changes depending on asynchronous generator and frequency of the system is continuously in oscillation position. To obtain maximum benefit from the wind energy, variable speed wind turbines are being used in general. Variable speed wind turbine systems produce variable voltage and frequency when no controller element is used. In order to obtain output voltage and frequency in desirable values from

variable speed wind generation systems, they must be operated together with the controller element. Output power obtained from the wind turbine system changes throughout the day, depending on wind speed. In very large and powerful networks, changes and oscillations in wind output power is minimized or eliminated by controlling the frequency and voltage. In wind power generation systems isolated from networks, a power balance between generation and consumption within previously determined power limits must be ensured and voltage and frequency must be kept in desirable values.

2.Literature

The wind energy conversion system is a complex system that converts wind energy to mechanical energy and electric energy. Output power or moment of wind turbine is defined with basic factors such as wind speed, turbine shape and dimension. The dynamic model of a wind turbine must contain parameters defining the behavior of wind turbine. With operation of so established wind turbine, it is possible to control the performance of wind turbine to obtain desired characteristics. In respect to wind power generation, turbines having different characteristics play important role in power generation. The air dynamic or wind turbine model is performed depending on the air dynamic power productivity coefficient $C_p(\theta, \lambda)$ or torque coefficient $C_q(\theta, \lambda)$, where θ is the blade pitch angle and λ is the speed rate. Output moment of the wind turbine model (air dynamic model) is determined depending on wind speed. In Figure 1, dynamic behavior model of wind turbine and mechanical system is given. Output power of wind turbine is multiplied by a definite gain coefficient (gear number) for stable operation of the moment system produced depending on blade pitch angle and turbine rotor speed rate and so, shaft moment is kept in desirable value. As the shaft of wind turbine and shaft of asynchronous generator is coupled to each other, the generator can be operated in desired operation speed.

Figure 1 The wind turbine and dynamic behavior model of mechanical system Inputs and outputs of wind turbine are defined as follows The wind speed is expressed as an independent input. It is defined as energy input to wind turbine. Specific (special) magnitudes of turbine are defined as input parameter. Magnitudes belong to turbine speed, rotor blade pitch and rotor blade gap angle form the transmission Parameters of the wind energy conversion system. Wind turbine output magnitudes are defined as power

and propeller moment. With determination of input and output variables of the wind turbine, expressions relating input and output variables can be easily obtained. Equations defining relations between the obtained power and blade speed are related to the mechanical power in moving air flow and can be expressed as flow rate of kinetic energy per second:

$$P = 1/2(\rho AV) V^2 = 1/2\rho AV^3 \text{ Watt} \quad (1)$$

Here, P is the mechanical power in the moving air (watt), ρ is air density (kg/m^3), A is area swept of the rotor blades (m^2), and V is velocity of the air (m/sc). The mechanical power extracted by the blades is expressed as a fraction of the upstream as

$$P = 1/2\rho \cdot A \cdot V^3 \cdot C_p \quad (2)$$

To integrate the best features of Fuzzy Systems and Neural Networks: From FS: Representation of prior knowledge into a set of constraints (network topology) to reduce the optimization search space From NN: Adaptation of back propagation to structured network to automate FC parametric tuning. Application to synthesize: controllers (automated FC tuning) models (to explain past data and predict future behaviour). A high level representation language with local semantics and an interpreter/compiler to synthesize non-linear (control) surfaces.

3.Methodology

3.1Wind-solar hybrid power generation system with battery support

The hybrid power generation systems are the power generation systems that are established by parallel connection of two or more traditional or renewable power generation systems. The hybrid power generation systems are the best solution methods to meet the electric energy needs of mini networks and small settlements far from energy generation and distribution centers. The wind-solar hybrid power generation system is the most commonly used system [13, 14].

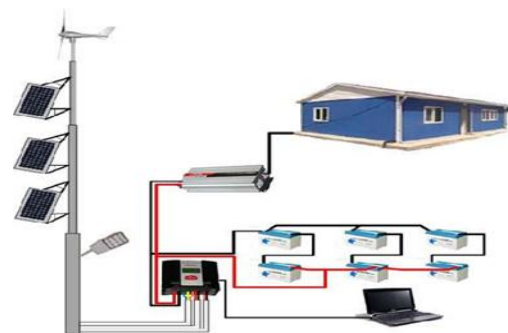

Figure 1 General view of the wind-solar hybrid power generation system with battery support

General view of the installed wind-solar hybrid power generation system with battery support is given in Figure 1. The installed hybrid power generation system consists of 600W wind turbine, 190W 3 pieces solar panels, a battery group and 1200W hybrid charge control unit that ensures congruent operation of these units and 3kW full sinus wave inverter for consumers fed with alternative current. Besides, data related the energy generated at the hybrid power generation system can be followed via charge control unit in 10 sec intervals. As it can be seen Figure 2, dynamic modeling of the hybrid power generation system in conformity with its behavior in real time was realized by using the Sim Power Systems in the Matlab/Simulink program. Then, output voltage of WPGS was regulated with AC-DC power converter and output voltage of SPGS with DC-DC power converter to DC 24V and connected to DC bar parallel including the battery group, and hybrid power generation system was established.

As it can be seen Figure 3, dynamic modeling of the hybrid power generation system in conformity with its behavior in real time was realized by using the Sim Power Systems in the Matlab/Simulink program. Then, output voltage of WPGS was regulated with AC-DC power converter and output voltage of SPGS with DC-DC power converter to DC 24V and connected to DC bar I including the battery group, and hybrid power generation system was established.

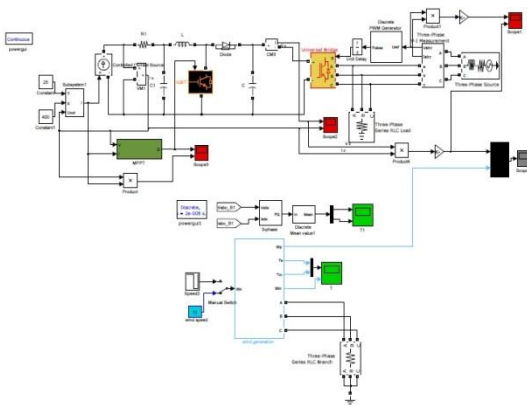

Figure 2 Simulation and modeling of Hybrid PV-Wind Model

3.2 Modelling and simulation of hybrid PV-solar model for MPPT

For RES especially the variable speed wind energy conversion systems, Permanent Magnet Synchronous generator (PMSG) is gaining popularity. PMSG have a loss-free rotor, and the power losses are confined to

the stator winding and stator core. A multi-pole PMSG connected to power converter can be used as direct driven PMSG in locations with low wind speed there by eliminating the gearbox which adds weight, losses, cost and maintenance [16]. A gearless construction of wind conversion system represents an efficient and reliable wind power conversion system. In a PV system, a solar cell alone can produce power of 1 to 2 watt [17]. The solar cell is modeled by two diode model [18]. The solar cells are connected in series and parallel to form a PV panel or module. The PV modules are connected in series and parallel to form a PV array in order to generate appropriate amount of power. Thus a PV system consisting of PV array, Maximum Power Point Tracking (MPPT) boost converters, and Wind power system consisting of wind turbine, PMSG, rectifier and MPPT boost converter is integrated into Solar Wind hybrid power system (SWHPS). The efficiency and reliability of the SWHPS mainly depends upon the control strategy of the MPPT boost converter. The solar and wind power generation cannot operate at Maximum power point (MPP) without proper control logic in the MPPT boost converter.

If the MPP is not tracked by the controller the power losses will occur in the system and in spite of wind and solar power availability, the output voltage of the hybrid system will not boost up to the required value [15]. The output voltage of the PV and Wind power generation are quite low as compared with the desired operating level. So, this output voltage is brought to desired operating value of 220V using Boost converter with MPPT controller at each source. The control logic of the MPPT controlled boost converter for the Wind power generation and PV based generation are selected on the basis of ease of implementation and robustness.

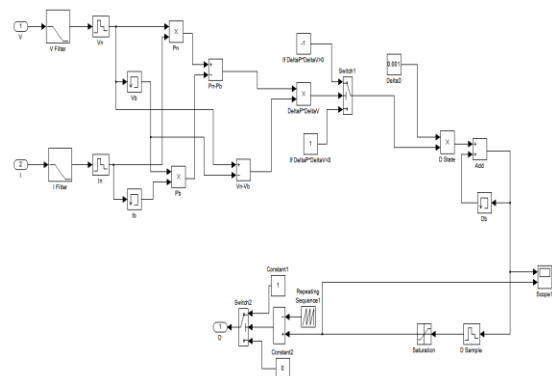

Figure 3 Modelling and Simulation of Hybrid PV-Solar Model for MPPT

3.3 Modelling and simulation form variable wind power generation system

The wind turbine, special analysis of mechanical machine and correlations defining dynamic behaviour of the device is explained in element in previous bankruptcy. Within the have a look at completed for reason for acquiring the dynamic behaviour of the wind energy generation device in actual time, Sim strength systems program worried inside the Matlab/ Simulink was used. Earlier than giving the simulation block diagram of the wind strength generation system, a simplified block diagram of the device is given in Figure 4.

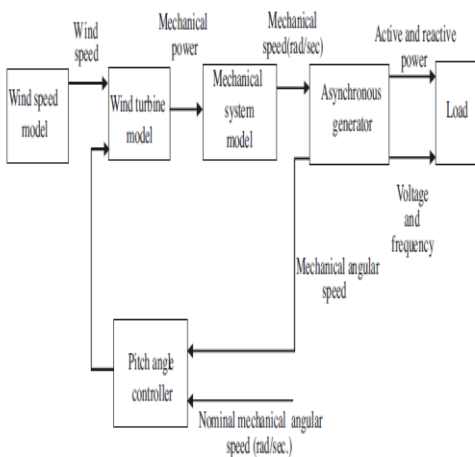

Figure 4 Simplified block diagram of the variable-speed wind power generation system

On this diagram, output of the wind velocity model is described as kinetic energy or pace of wind. The wind pace is transformed to mechanical strength or second by the wind turbine model. The received mechanical energy or second is the primary enter of the mechanical device (impulse gadget). Other second enter of the mechanical system is the proportional velocity of asynchronous generator. Output of the automated machine is the wind turbine rotor speed and mechanical power. Inputs of the asynchronous generator model are mechanical electricity acquired from the wind turbine, voltage at community or recommendations of load and frequency magnitudes. Outputs of asynchronous generator are network or energetic and reactive electricity values essential for the burden. Voltage and frequency of asynchronous generator also can be given in output magnitudes within the wind electricity era systems that operate in isolation to electric powered networks. Within the examiner, information on MWT-300 kW variable velocity and

three-blade wind turbine synthetic by using Mitsubishi heavy industry has been employed. The wind pace of that wind turbine (m/s) and curve of produced output energy is given in Figure 2 [15].

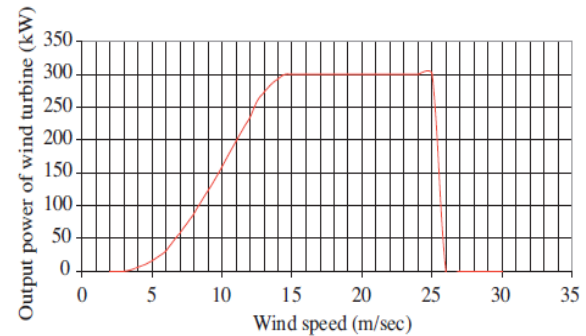

Figure 5 The curve of produced output power of MWT-300 kW wind turbine depending on wind speed

In Figure 6 Beneath, a simulation block diagram of the wind power generation system performed via Mat lab/Simulink software is given. The wind electricity era machine consists of primary compounds consisting of squirrel cage asynchronous generator, synchronized condenser, variable pace wind turbine, load, frequency control unit, sell off load, ammeter and voltmeter. Because the equations and formulations related to dynamic modelling of the asynchronous generator and synchronized condenser that shape the wind electricity production system will take a large location in this look at, they're no longer given here. Within the matlab software, modelling of the asynchronous generator and synchronized condenser is executed via the formulation given in reference [16–23].

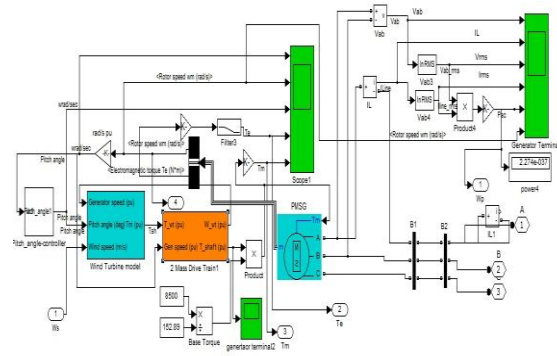

Figure 6 Simulation Block Diagram of the variable-speed wind power generation system without Fuzzy logic obtained through Mat lab/Simulink program [15]

Inside the block diagram of the wind energy manufacturing gadget given in parent 4, the output of the wind velocity model is described because the kinetic strength or speed of wind. The wind pace is transformed to mechanic strength or second by means of the wind turbine version. The obtained mechanic power or moment is the primary input of the mechanic system (of pressure machine). The alternative second input of the mechanic machine is the proportional speed of the asynchronous generator. Inputs of the asynchronous generator are: mechanical power obtained from the wind turbine, voltage and frequency magnitudes at ends of the network or load. Outputs of the asynchronous generator are the energetic and reactive strength values required for the community or load. Within the wind strength manufacturing structures that operate in remoted way from electric powered networks, voltage and frequency of the asynchronous generator may be expressed as output magnitudes. The simulation block diagram completed in Mat lab/Simulink program for dynamic working situation of the wind strength manufacturing machine is proven in parent four. The wind strength manufacturing gadget consists of simple additives consisting of squirrel cage asynchronous generator, synchronized condenser, variable velocity wind turbine, load,

frequency manipulate unit, unload-load, ammeter and voltmeter. The detailed block model of the wind power production system given in Figure 4 above is shown in Figure 5 below. In this wind power production system, variations in frequency, output voltage and drawn power curves of the system are obtained individually by means of the simulation study without any controller element. Different power demands of consumers are Amplitude of the voltage acquired from the gadget need to be within permitted limits whatever the electric electricity production gadget is used. It's miles known that frequency of the device in other vital importance is 50Hz in Turkey running situations. The machine frequency in electric electricity production stations is attempted to be stored in 50Hz fee. To acquire high satisfactory strength, the importance values of frequency and voltage need to be kept in the desired variety. Best of obtained by electricity can be introduced to desire degree via the undesired harmonic currents and voltages to minimum level. By using thinking about the situation the wind power manufacturing machine will function with the network, the frequency and voltage price is adjusted consistent with the frequency and voltage values of the community.

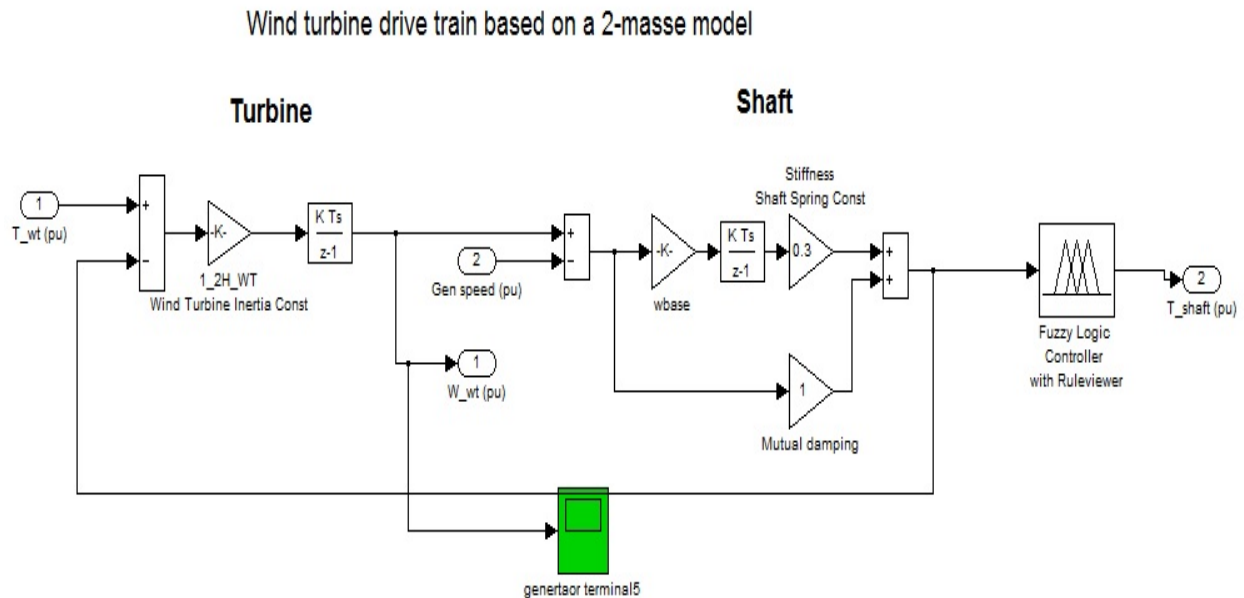

Figure 7 Simulation block diagram of wind power generation system with fuzzy logic

The wind energy production device includes asynchronous generator, synchronized condenser and wind turbine is given in determining 4. The synchronized condenser is equal with the

synchronized device we realize. If it's miles operated as a condenser, its mechanic power enter is zero. In other words, it isn't essential to actuate it with a driving device. The reactive energy production is

ensured by means of adjusting the DC excitation circuit. The reason why we use a synchronized condenser within the wind power production device is to achieve magnetic modern or reactive electricity required in the operation of an asynchronous generator with wind turbine. Meanwhile, so one can be able to experience the impact of wind once more, feeding of synchronized condenser with the active power produced by means of asynchronous generator is finished.

3.4 Control strategy in wind power generation system

Output power acquired from the wind turbine varies throughout the day depending on versions of wind pace. Versions and oscillations inside the wind output energy can be decreased to minimal or eliminated absolutely by means of controlling the frequency and voltage in very massive and effective networks. Inside wind electricity production systems isolated from electric networks, the energy balance among manufacturing and consumption ought to be ensured and the frequency and voltage need to be stored inside previously determined energy limits. In order for the favored strength can be in decided fee and pleasant, the frequency and voltage values have to be among the approved lower and upper limits. Strength produced via the wind strength manufacturing machine cannot continually make sure the power stability between purchasers. If the intake power is much less than that wind power production gadget, by placing into operation the spare load agencies or dump-load circuit elements, the wind electricity is regulated and the frequency and voltage are done in the preferred amplitude. For the observer, the unload-load turned into used to govern the frequency. Management method of wind energy manufacturing structures includes phases:

- Speed control
- Power limitation control.

The speed control is considered as the main parameter within the strength optimization method. If the wind pace is lower than the rated wind speed, inclination angle is attempted to be kept at its most useful fee. In that state of affairs, in order for the generator velocity ω_{gen} to capture the most output energy of wind, the wind turbine pace is adjusted by using a controller. In energy quandary manipulate, the blade pitch perspective controller is made to equalize the nominal (rated) electricity with the produced power. In power limitation control loop, the mistake rate between the rated power cost and measured strength price is dispatched to the

controller element. The controller produces the vital reference the blade pitch attitude. This reference the blade pitch attitude is as compared to the real reference the blade pitch perspective. Because of this, output of power trouble controller, inclination attitude of wind turbine wings are decided. Inside the look at, depending at the real rotor velocity cost of the asynchronous generator in the wind strength manufacturing system, it's miles aimed to govern the turbine blade pitch attitude. With manipulate of the wing inclination angle, the energy problem manipulate is also executed. With control of the wing inclination angle of the wind turbine, the voltage and frequency is stored within the desired fee and so, the energy stability is ensured and saved.

4.Result

In hybrid power systems, a number of renewable energy generators and storage components are combined to meet the energy demand of the power system. It mainly includes PV generators and wind generators, the others sources of electrical energy can also be added to meet the energy demand. It is essential to know the energy demand and the resources available at that site before developing a hybrid power system. The energy planners must study the availability of solar energy, wind, and other potential resources at that site.

This will help them to design what kind of hybrid power system will be suitable to meet the demand. The overall Simulink model describes the Simulation diagram of the hybrid system in which PV system, wind energy system are connected through a power electronic controller in which it perform DC to DC transformation and AC to DC transformation and it is fed in to the PWM inverter for AC conversion and the system is connected to the grid and the loads. Here d-axis and q-axis voltages are taken as inputs to the FLC to get the desired dq-axis voltage then it is used to produce gate signals to the PWM inverter in which the voltage regulation is done.

Table 1 Voltage regulaton

	NL	NM	NS	Z	PS	PM	PL
NS	PS	PL	PL	PS	NM	NS	NM
NM	PM	PL	PL	PM	Z	Z	Z
NL	PL	PL	PL	PL	Z	Z	Z
Z	PS	PM	PL	Z	NS	NM	NL
PS	PS	PS	NM	NS	NS	NL	NL
PM	Z	Z	Z	NM	NM	NL	NL
PL	Z	Z	Z	NL	NL	NL	NL

We have introduced a fuzzy logic controller inside the driver circuit of the wind energy system.

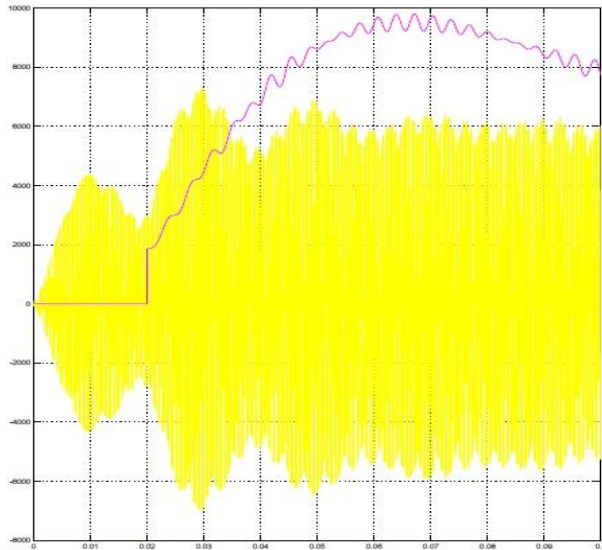

Figure 8 Circuit of the wind energy system

We have introduced a fuzzy logic controller inside the driver circuit of the wind energy system.

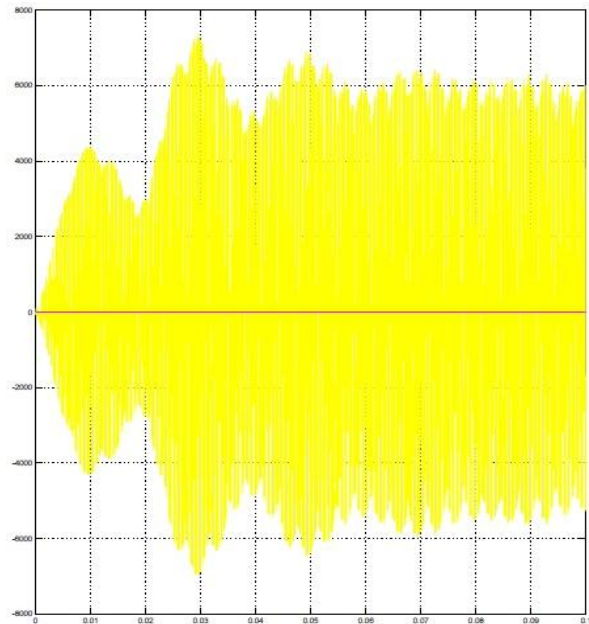

Figure 9 Circuit of the waveform

The waveforms shows the output of the hybrid PV and wind system at scope 4 which shows the output of PV cells in yellow and output of wind generation in pink. Fig. shows the output without fuzzy and Fig. Shows the output with fuzzy. It can be clearly seen

that the wind output has been stabilized with the implementation of fuzzy logic controller.

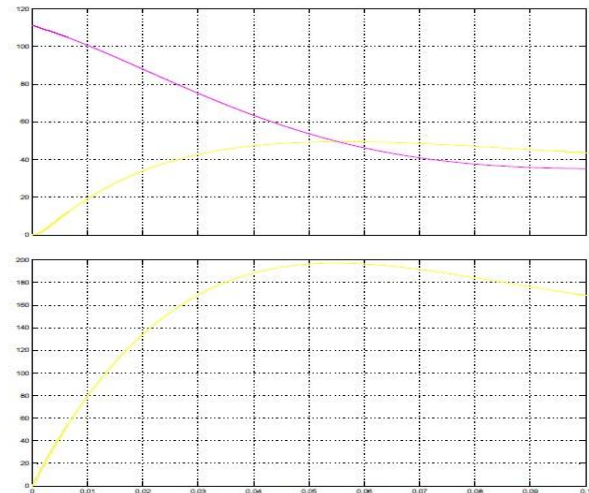

Figure 10 Scope T output with Fuzzy

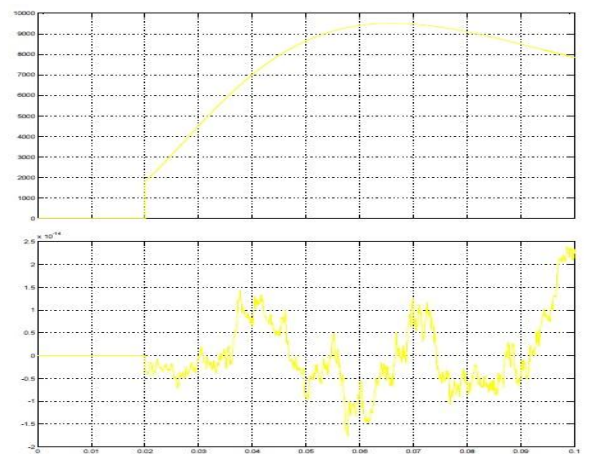

Figure 11 Scope T1 Output without Fuzzy

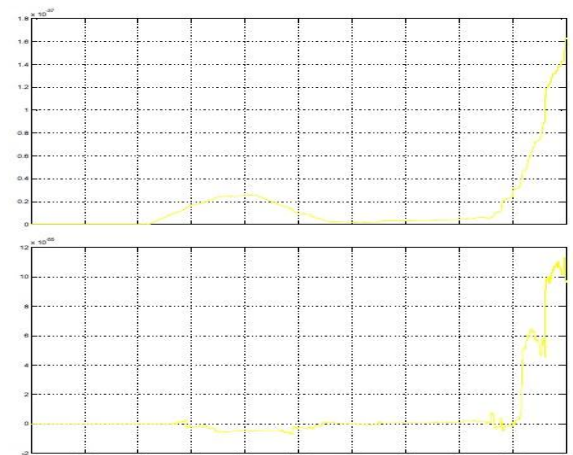

Figure 12 Scope T1 Output with Fuzzy

5. Conclusion

This will help them to design what kind of hybrid power system will be suitable to meet the demand. The overall Simulink model describes the Simulation diagram of the hybrid system in which PV system, wind energy system are connected through a power electronic controller in which it perform DC to DC transformation and AC to DC transformation and it is fed in to the PWM inverter for AC conversion and the system is connected to the grid and the loads. Here d-axis and q-axis voltages are taken as inputs to the FLC to get the desired dq-axis voltage then it is used to produce gate signals to the PWM inverter in which the voltage regulation is done, it's seen that operational performance of the system is among wakefully smart price. Meanwhile, no downside concerning compatibility of Fuzzy logic controller with Hybrid PV/WPGS solar has been practiced. A contrary, electrical output magnitude in fascinating quality and output is obtained.

References

- [1] Natsheh EM, Albarbar A, Yazdani J. Modeling and control for smart grid integration of solar/wind energy conversion system. In innovative smart grid technologies (ISGT Europe), 2nd IEEE PES international conference and exhibition on 2011 (pp. 1-8). IEEE.
- [2] Billinton R. Evaluation of different operating strategies in small stand-alone power systems. IEEE Transactions on Energy Conversion. 2005; 20(3):654-60.
- [3] Shaahid SM, Elhadidy MA. Opportunities for utilization of stand-alone hybrid (photovoltaic+ diesel+ battery) power systems in hot climates. Renewable Energy. 2003; 28(11):1741-53.
- [4] Calderaro V, Galdi V, Piccolo A, Siano P. A fuzzy controller for maximum energy extraction from variable speed wind power generation systems. Electric Power Systems Research. 2008; 78(6):1109-18.
- [5] Kocatepe C, İnan A, Arıkan O, Yumurtacı R, Kekezoğlu B, Baysal M, et al. Power quality assessment of grid-connected wind farms considering regulations in turkey. Renewable and Sustainable Energy Reviews. 2009; 13(9):2553-61.
- [6] Gaillard A, Poure P, Saadate S, Machmoum M. Variable speed DFIG wind energy system for power generation and harmonic current mitigation. Renewable Energy. 2009; 34(6):1545-53.
- [7] Fard AT, Ildarabadi R, Zadehbagheri M. Optimal production planning of wind and thermal power plants with respect to constraints on transmission line and taking into account the uncertainty of wind. International Journal of Advanced Computer Research. 2015 Mar 1;5(18):52.
- [8] International electrotechnical commission. electromagnetic compatibility (EMC)-Part 4-30: testing and measurement techniques-power quality measurement methods. IEC 61000-4-30. 2003.
- [9] Morales A, Robe X, Maun JC. Wind turbine generator systems-part 21: measurement and assessment of power quality characteristics of grid connected wind turbines. IEC/CEI. 2001;61400:21.
- [10] Slootweg JG, Kling WL. Impacts of wind power on power system Dynamics. Wind power in power systems. 2005:629-51.
- [11] Ledesma P, Usaola J, Rodriguez JL. Transient stability of a fixed speed wind farm. Renewable Energy. 2003; 28(9):1341-55.
- [12] Ko HS, Lee KY, Kang MJ, Kim HC. Power quality control of an autonomous wind–diesel power system based on hybrid intelligent controller. Neural Networks. 2008; 21(10):1439-46.
- [13] Moubayed N, Kouta J, El-Ali A, Dernayka H, Outbib R. Parameter identification of the lead-acid battery model. In photovoltaic specialists conference. PVSC'08. 33rd IEEE 2008 (pp. 1-6). IEEE.
- [14] Valenciaga F, Puleston PF, Battaiotto PE. Power control of a solar/wind generation system without wind measurement: A passivity/sliding mode approach. IEEE Transactions on Energy Conversion. 2003; 18(4):501-7.
- [15] El-Ali A, Moubayed N, Outbib R. Comparison between solar and wind energy in Lebanon. In electrical power quality and utilisation, 2007. EPQU 2007. 9th international conference on 2007 (pp. 1-5). IEEE.
- [16] Morgan TR, Marshall RH, Brinkworth BJ. 'ARES'-A refined simulation program for the sizing and optimisation of autonomous hybrid energy systems. Solar Energy. 1997; 59(4-6):205-15.
- [17] Diaf S, Diaf D, Belhame M, Haddadi M, Louche A. A methodology for optimal sizing of autonomous hybrid PV/wind system. Energy Policy. 2007; 35(11):5708-18.
- [18] Mittal R, Sandhu KS, Jain DK. Battery energy storage system for variable speed driven PMSG for wind energy conversion system. In Power electronics, Drives and energy systems (PEDES) & Power India, Joint international conference on 2010 (pp. 1-5). IEEE.