

Harmonics reduction in micro grid application using both PI controller and APF technique

Akashdeep Soni¹ and Vikash kumar²

M.Tech, Scholar, Department of Electrical Engineering, LNCT, Bhopal¹
Associate Professor, Department of Electrical Engineering, LNCT, Bhopal²

Abstract

The Non-linear loads are suddenly increased or decreased in the distribution systems. These loads can be shown as non-sinusoidal currents from the AC mains and causes the load harmonics and reactive power, and excessive neutral currents. These Harmonics gives pollution in the power systems. Hence these non-linear loads created many pollution problems in the power systems. These type of problem prevents fast switching for power electronic devices. Here we use Shunt active filter which is based on current controlled PWM converters are seen as a most viable solution. The reactive power compensation and harmonics presents in this paper by IP controlled shunt active from 3P4W micro-grid distribution system. By using this technique we generate desired compensation current extraction based on offset command instantaneous currents distorted or voltage signals in the time domain because compensation time domain response is quick, easy implementation and lower computational load compared to the frequency domain.

Keywords

Voltage disturbances, Nonlinear loads, PCC, Power quality, Shunt active Power filter (SAPF), PWM.

1.Introduction

The Non-Linear loads has been introduced into distribution systems such as transformers, computers, saturated coils and increases sophisticated power electronic devices in daily use. Power electronics devices create most of the pollution Due to its nonlinear characteristics and fast switching techniques. By increasing in such non-linearity causes many problem like low system efficiency and poor power factor. It also affect to other consumers. Hence it is very important to overcome these desirable features. The harmonics are used to suppress by The shunt passive filters which is consist of tuned LC filters and high passive filters. The power capacitors are employed to improve the power factor. But they have the limitations of fixed compensation, large size and can also exile resonance conditions. So we can say that active power filters is the best alternative over the classical passive filters, to reimburse harmonics and reactive power requirement of the non-linear loads[1-5].

There are Various topologies of active power filters have been developed so far. The converter which is similar to the shunt active power filter that has been proved to be effective even when the load is highly nonlinear. There are Most of the active filters developed are based on sensing harmonics. An instantaneous reactive volt-ampere compensator and harmonic suppressor system is proposed without the use of voltage sensors but require complex hardware for current reference generator. However, the conventional PI controller was used for the generation of a reference current template. A linear mathematical models which is PI controllers are described, to perform satisfactorily under parameter variations which are difficult to obtain and fails, nonlinearity, load disturbance, etc.

The PI controlled shunt active power filter implemented for the harmonics reduction and reactive power compensation of a nonlinear load are. This type of control scheme is based on sensing line currents. The DC capacitor voltage is regulated to estimate the reference current template form system. The role of the DC capacitor is described to estimate the reference current. A design criterion is described for the selection of power circuit components. The performance of both the controllers is investigated and both the control schemed is to be compared [6-8].

2.Topologies of power filter

The Active power filters can be implemented as shunt type, series type, or a combination of shunt and series active filters. The passive filters to create hybrid power filters with the active power filters. The shunt-connected active power filter shows the characteristics similar to STATCOM (reactive power compensator of power transmission system) when used with self-controlled dc bus. The shunt active power filters, acts as a current source, injects harmonic compensating current of same magnitude as the load current harmonics but shifted in phase by 180° and thus compensates load current harmonics. These are used for low -power applications. These filters can be used as a substitute to UPS with

comparatively very low cost as no energy storing element like battery is used. Moreover overall rating of components is smaller. In series-shunt active filter the shunt active filter is located at the load side and can be used to compensate for the load harmonics, reactive power, and load current unbalances. And the series filter is at the source side and can act as a harmonic blocking filter. Other advantage of this topology is regulates the dc link capacitor voltage. The power required by the series compensator in which power supplied or absorbed by the shunt.

Multilevel inverters are based on hybrid AC filter and recently used for active filter topologies. Three phase four wire inverters are becoming very popular for most inverter applications like machine drives and power factor compensators. The benefit of multilevel converters is that they can decrease the harmonics content generated by the active filter.

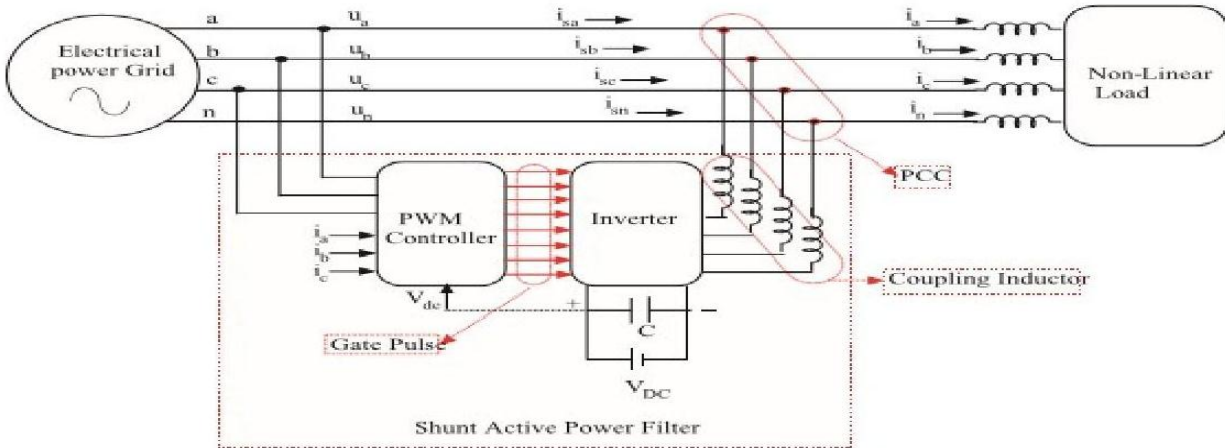

Figure 1 Shunt active power filter topology

Because multilevel converters can produce more levels of voltage than other converters. This feature helps to reduce the harmonics generated by the filter power itself. One more advantage is that they can reduce the voltage or current ratings of the semiconductors and the switching frequency requirements.

3.Active power filters as source converters

The active power filter topologies are often used as a voltage source converters. The topology depicted in Figure 1, converts a dc voltage into an ac voltage by appropriately gating the power semiconductor switches. A single pulse for each half cycle can be applied to synthesize an ac voltage. For the purposes of dynamic performance, pulse width modulation is the most commonly used in active power filter. PWM techniques are applied to control the VSI that chop the dc bus voltage to produce an ac voltage of an arbitrary waveform.

Voltage source converters are preferred because have higher efficiency and lower initial cost than the current source converters [3, 4, 9-11]. They can also

be expanded in parallel to increase their combined rating and their switching rate can be increased if they are carefully controlled so that their individual switching times do not coincide. Therefore, higher-order harmonics can be eliminated by using converters without increasing individual converter switching rates. The instantaneous load is product of source voltage and load current, expressed as.

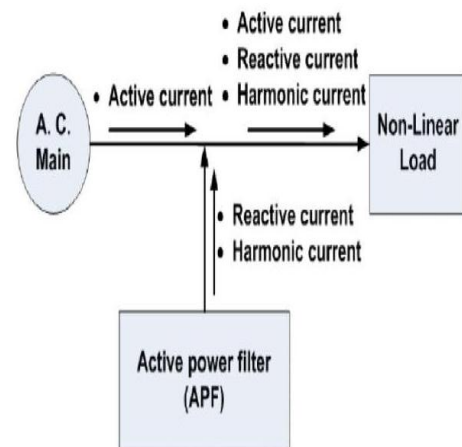

Figure 2 Principle of shunt active power filter

4. Voltage source inverter

The PWM-voltage source inverter is more advantageous for shunt active power line conditioner applications, on account of light-weight, less expensive, and expandable to multilevel topologies to enhance its execution for higher power rating compensation with bring down exchanging frequencies. The structure of the voltage source inverter is appeared in Figure 3. It is worked by utilizing six-controllable power transistors with hostile to parallel diodes. The voltage source inverter works as present controlled voltage source. Routinely, two-level voltage source inverter has been utilized to associate the system to the ac mains through an interface inductor (transformer). An electrolytic capacitor keeps up the dc-voltage steady and swell free. This sort of setup is intended to repay non-direct load appraised in the medium power go (100 kVA) because of semiconductors evaluated esteem constraints. Be that as it may, the multilevel or cascaded PWM-VSI have been produced to active power line conditioner for medium voltage and higher appraised power applications.

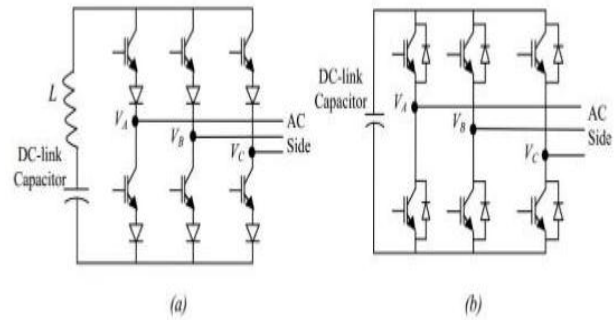

Figure 3 (a) Current source inverter and (b) Voltage source inverter

The shunt active power filter model is developed and simulated in MATLAB with PWM based PI controller. The complete active power filter system consists of mainly a voltage source PWM converter, a non-linear load, a three-phase source and PI controller. All these components are modeled separately, integrated and then solved to simulate the system. In modelling PI control scheme the error signal is fed to PI controller.

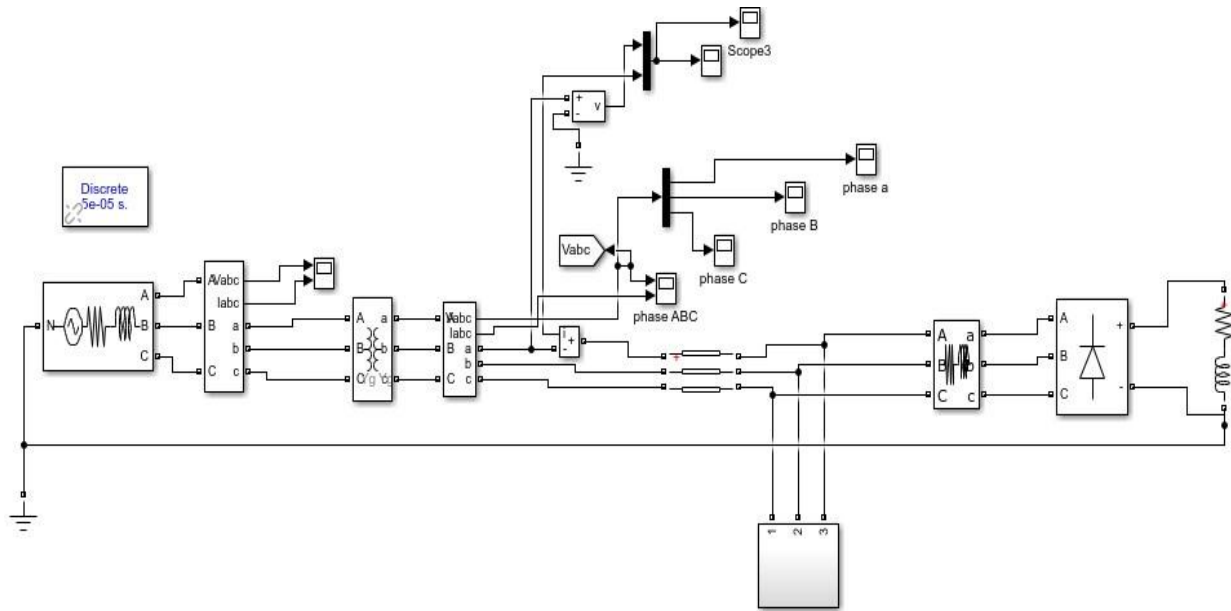

Figure 4 Proposed methods

The peak value of the reference current. It is further multiplied by the unit sine vectors (u_{sa} , u_{sb} , and u_{sc}) in phase with the source voltages to obtain the reference currents (i_{sa}^* , i_{sb}^* , and i_{sc}^*). These reference currents and actual currents are given to a hysteresis based, carrier less PWM current controller to generate switching signals of the PWM converter.

5. Results

The shunt active power filter modal is developed and simulate in MATLAB with PWM based PI controller. The complete active power filter system is composed mainly of three-phase source, a non-linear load, a voltage source PWM.

Converter and a PI controller. All these components are modeled separately, integrated and then solved to

simulate the system. The THD in the load current is 28%.

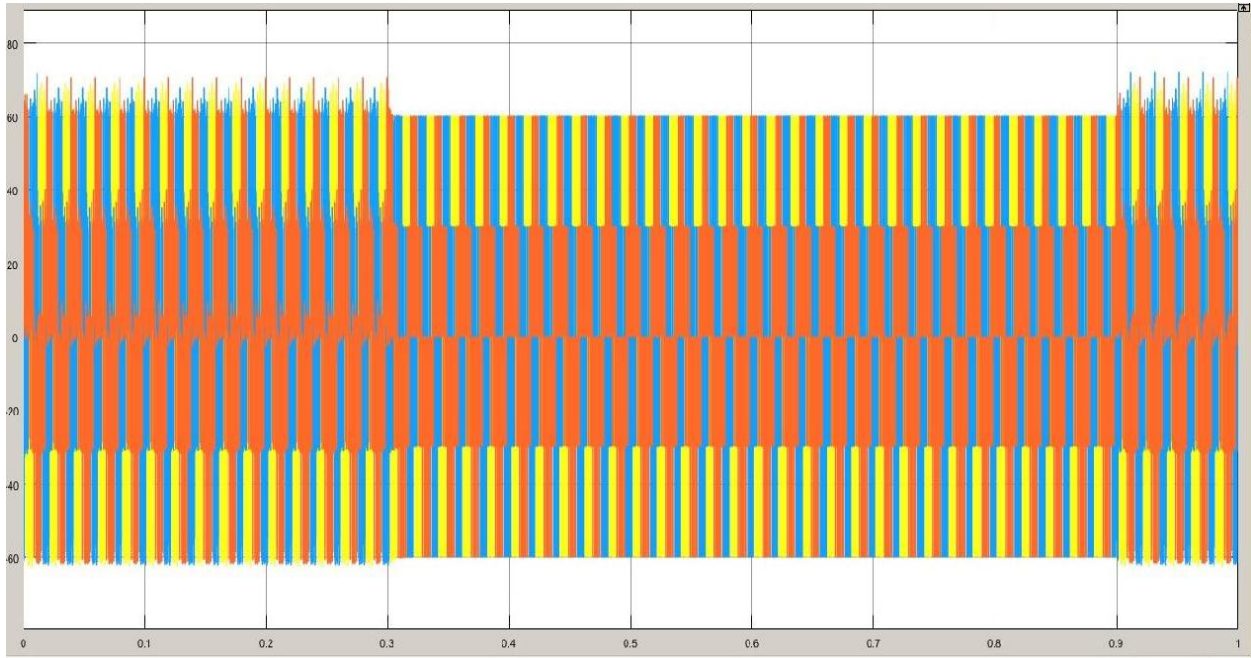

Figure 5 Source Voltage waveforms of the system

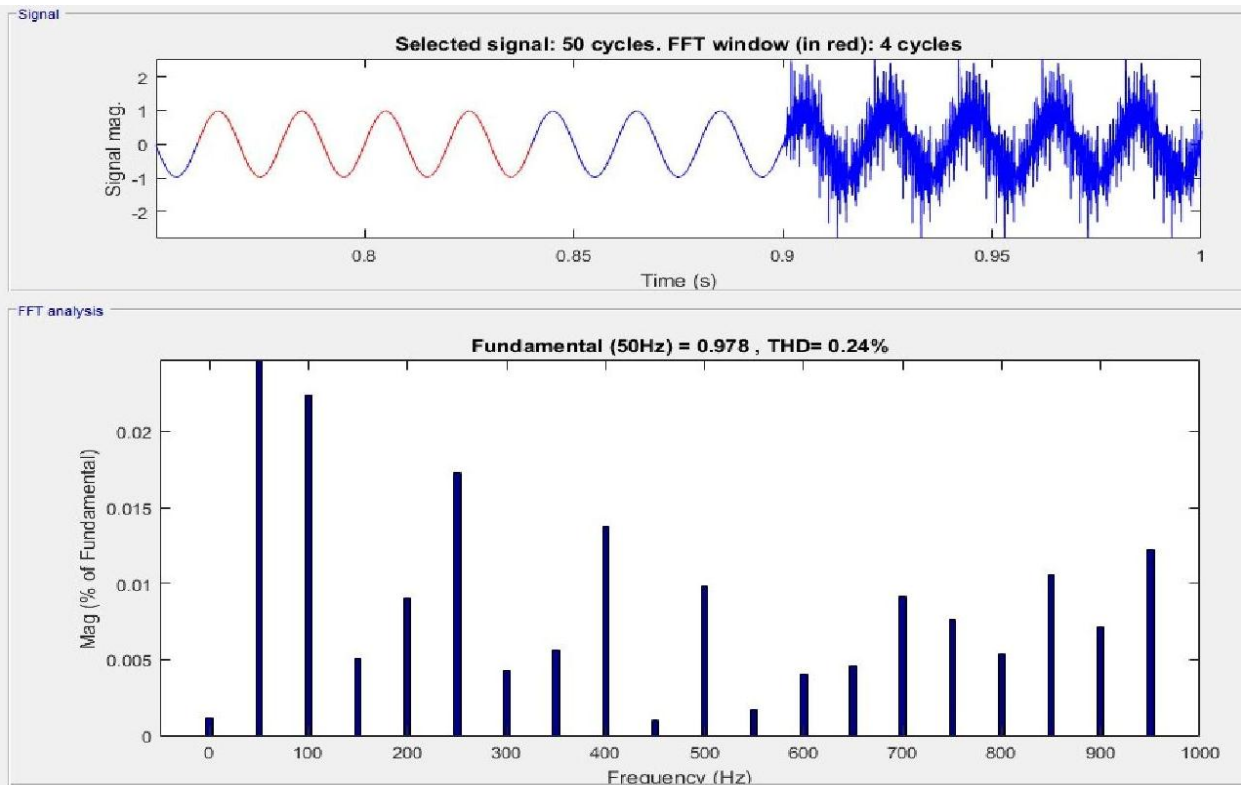

Figure 6 Source Voltage waveforms of the system Value

The compensator is switched ON at $t = 0.3s$ and the integral time square error performance index is used as coefficients of the PI controller. The and 1.2, respectively, which corresponds to the minimum value of ITSE. In this case we have to absorb Total Harmonics Distortion (THD) is The settling time required by the PI controller is approximately 8 cycles. The source current THD is below by the comparison of IEEE standard with both the controllers it is reduced near to 1% with PI compensation. Simulation extraction of harmonics and adjustable accuracy and speed of response are another superior advantages of this proposed technique. It has been shown that the proposed technique is suitable for extraction of selective and/or wide range harmonic content of the injected current and the voltage at the point of common coupling (PCC) and also it has been shown that the proposed technique is appropriate for selective or wide range current harmonic compensation.

Table 1 Voltage source of non-linear load

Current	THD(%) before compensation	THD(%) after PI Control
Phase A	9.25	0.24
Phase B	15.25	0.24
Phase C	7.25	0.23

6. Conclusion

In the paper, PI controller based shunt active power filter simulated in MATLAB are implemented for harmonic and reactive power compensation of the non-linear load at PCC. It is found from the simulation results that shunt active power filter improves power quality of the distribution system by eliminating harmonics and reactive power compensation of non-linear load. It in turn makes the load current sinusoidal and in phase with the source voltage. The THD of the source current is below 1%.

References

- [1] Anjana P, Gupta V, Tiwari H. Reducing harmonics in micro grid distribution system using APF with PI controller. In T&D Conference and Exposition, 2014 IEEE PES 2014 (pp. 1-5). IEEE.
- [2] Salmeron P, Montano JC, Vázquez JR, Prieto J, Pérez A. Compensation in nonsinusoidal, unbalanced three-phase four-wire systems with active power-line conditioner. *IEEE Transactions on Power Delivery*. 2004; 19(4):1968-74.
- [3] Orts-Grau S, Gimeno-Sales FJ, Abellan-Garcia A, Segui-Chilet S, Alfonso-Gil JC. Improved shunt active power compensator for IEEE standard 1459 compliance. *IEEE Transactions on Power Delivery*. 2010; 25(4):2692-701.
- [4] Herrera RS, Salmerón P. Instantaneous reactive power theory: a comparative evaluation of different formulations. *IEEE Transactions on Power Delivery*. 2007; 22(1):595-604.
- [5] Herrera RS, Salmerón P, Kim H. Instantaneous reactive power theory applied to active power filter compensation: different approaches, assessment, and experimental results. *IEEE Transactions on Industrial Electronics*. 2008; 55(1):184-96.
- [6] Li Y, Vilathgamuwa DM, Loh PC. Microgrid power quality enhancement using a three-phase four-wire grid-interfacing compensator. *IEEE Transactions on Industry Applications*. 2005; 41(6):1707-19.
- [7] Elmitwally A, Abdelkader S, El-Kateb M. Neural network controlled three-phase four-wire shunt active power filter. *IEE Proceedings-Generation, Transmission and Distribution*. 2000; 147(2):87-92.
- [8] Barrado JA, Grino R, Valderrama-Blavi H. Power-quality improvement of a stand-alone induction generator using a STATCOM with battery energy storage system. *IEEE Transactions on power delivery*. 2010; 25(4):2734-41.
- [9] Ciric RM, Feltrin AP, Ochoa LF. Power flow in four-wire distribution networks-general approach. *IEEE Transactions on Power Systems*. 2003; 18(4):1283-90.
- [10] Lam CS, Wong MC, Han YD. Hysteresis current control of hybrid active power filters. *IET Power Electronics*. 2012; 5(7):1175-87.
- [11] Khadkikar V. Enhancing electric power quality using UPQC: A comprehensive overview. *IEEE transactions on Power Electronics*. 2012; 27(5):2284-97.